

CASA COLLINA  
RAMSEY COUNTY, MINNESOTA

APACHE ENGINEERING COMPANY  
ENGINEERS & LAND SURVEYORS

KNOW ALL MEN BY THESE PRESENTS: That Luke J. Tieso and Virginia F. Tieso, husband and wife, owners and proprietors, and Northern Federal Savings and Loan Association, A United States of America Corporation, mortgagee of the following described property lying and being in the County of Ramsey, and the State of Minnesota, to wit:

That part of Tract "B", Registered Land Survey No. 90, Ramsey County, Minnesota, lying Northerly of the following described line: Commencing at the most Southeasterly corner of said Tract "B", thence North 12 degrees, 50 minutes West on the Easterly line of said Tract "B" for a distance of 319.34 feet (as shown on said Registered Land Survey No. 90); thence West on the boundary of said Tract "B" for a distance of 348.8 feet to a corner of said Tract "B" for actual point of beginning of line to be described; thence Northwesterly to the intersection of the Westerly line of said Tract "B" and the Southerly line of the Northeast 1/4 of Section 23, Town 30 North, Range 23 West and there terminating.

All that part of Government Lots Four (4) and Five (5) in Section Twenty-Three (23), Town Thirty (30) North, Range Twenty-Three (23) West, described as follows: Beginning at a point on the Southwesterly line of Reiland Lane at its intersection with the Southeasterly line of Lot Three (3), Reiland's Lake Shore extended 30.18 feet Southwesterly from the most Southerly corner of said Lot Three (3); thence continuing on said Southeasterly line of said Lot Three (3) extended 225.0 feet; thence Northwesterly parallel with the Southwesterly line of Reiland Lane 75.47 feet; thence Northwesterly parallel with the first mentioned course 225.0 feet to a point on the Southwesterly line of Reiland Lane extended; thence Southeasterly on said Southwesterly line of Reiland Lane 75.47 feet to the point of beginning. Subject to an easement over the Northeasterly 20.0 feet thereof which will be used in the future for the widening of Reiland Lane.

Lots One (1), Two (2), Three (3), Four (4), and Five (5) and that part of Lots Six (6) and Seven (7) lying Southeasterly of a line drawn between the Northeast corner of said Lot Six (6) and the Southwest corner of said Lot Seven (7), in Block Four (4) Baken Addition No. 2, according to the plat thereof filed and of record in the office of the Register of Titles within and for said county. Have caused the same to be surveyed and platted as CASA COLLINA, and do hereby donate and dedicate to the public for the public use forever the drive, lane, and utility easements as shown on the plat; subject to a blanket easement for utility and drainage purposes, overhead utilities are not included, over Lot One (1), Block Nine (9) as shown on the plat.

IN WITNESS WHERE OF:

We Luke J. Tieso and Virginia F. Tieso, husband and wife, have here unto set our hands and seals this 6th day of April, 1973 A.D.

IN WITNESS WHERE OF:

Northern Federal Savings and Loan Association, A United States of America Corporation, has caused these presents to be signed by its proper officers this 9th day of April, 1973 A.D.

IN PRESENCE OF:

Richard J. Kramer  
Witness

William J. Laska  
Witness

Harry D. Lee  
Witness

Alfred J. McComber  
Witness

BY: Luke J. Tieso  
Luke J. Tieso

BY: Virginia F. Tieso  
Virginia F. Tieso

IN PRESENCE OF:

Lorraine J. Engen  
Witness

M. Hedlund  
Witness

Lorraine J. Engen  
Witness

M. Hedlund  
Witness

NORTHERN FEDERAL SAVINGS AND  
LOAN ASSOCIATION  
BY: Morris M. Hedlund  
It's Executive Vice President

BY: Alfred J. McComber  
It's Assistant Secretary

STATE OF MINNESOTA

COUNTY OF Ramsey

On this 6th day of April, 1973 A.D., before me, a notary public, within and for said County and State, personally appeared Luke J. Tieso and Virginia F. Tieso, husband and wife, to me known to be the persons described in and who executed the foregoing instrument and they acknowledge that they executed the same as their own free act and deed.

Bernice C. Tieso  
Notary Public Ramsey County, Minnesota  
My Commission Expires Jan. 27, 1977

STATE OF MINNESOTA

COUNTY OF Ramsey

On this 9th day of April, 1973 A.D., before me, a notary public, within and for said County and State personally appeared Morris M. Hedlund and Alfred J. McComber, to me personally known, who being by me duly sworn, did say that they are respectively Executive Vice President and Assistant Secretary of Northern Federal Savings and Loan Association, A United States of America Corporation, named in the foregoing instrument and that the seal affixed to said instrument is the corporate seal of said corporation and that said instrument was signed and sealed in behalf of Northern Federal Savings and Loan Association by authority of it's Board of Directors and said Morris M. Hedlund and Alfred J. McComber acknowledged said instrument to be the free act and deed of Northern Federal Savings and Loan Association.

Lorraine J. Engen  
Notary Public Ramsey County, Minnesota  
My Commission Expires May 21, 1977

I hereby certify that I have surveyed and platted the property described on this plat as CASA COLLINA; that this plat is a correct representation of said survey; that all distances are correctly shown on the plat in feet and decimals of a foot; that all monuments have been correctly placed in the ground as shown on said plat; that all outside boundary lines are correctly designated on said plat and that there are no wet lands or public highways to be designated on said plat other than as shown.

Charles E. Dahlgron  
Surveyor, Minnesota Registration No. 3073

STATE OF MINNESOTA  
COUNTY OF Ramsey

Above certificate subscribed and sworn to before me, a notary public, within and for said County and State this 5th day of April, 1973 A.D.

Charles E. Dahlgron  
Notary Public Ramsey County, Minn.  
My Commission Expires Jan. 18, 1977

Approved by the Village Council of the Village of Shoreview, Minnesota, this 2nd day of APRIL, 1973 A.D.

Richard B. Hogan  
Village Clerk of Shoreview  
W. B. Farrell  
Mayor of Shoreview

Accepted and approved this 12th day of APRIL, 1973 A.D.

Walter A. Hartley  
George W. Engen  
Walter A. Hartley  
} Plat Commission

Richard J. McComber  
City Engineer of St. Paul

CASA COLLINA  
RAMSEY COUNTY, MINNESOTA

APACHE ENGINEERING COMPANY  
ENGINEERS & LAND SURVEYORS

NORTH

SCALE: ONE INCH=50 FEET  
O-DENOTES IRON MONUMENT  
BEARINGS SHOWN ARE ASSUMED

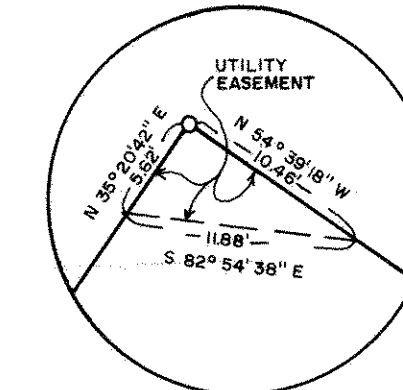

DETAIL OF UTILITY EASEMENT  
THROUGH BLOCK 2, LOT 3



WEST E S.E. 1/4 SEC. 23, T.30N., R.23W.

CENTER OF SEC. 23  
T.30N., R.23W.  
SOUTHERLY LINE  
OF N.E. 1/4

S.E. CORNER OF  
TRACT B

SOUTH LINE OF TRACT B R.L.S. NO. 90