

THOMAS WALSH'S RE-ARRANGEMENT

Scale 1" to 20'

Jens Pedersen
Surreyor

440871 *sl*

I hereby certify to having surveyed and platted the property as described on this map as Thomas Walsh's Re-Arrangement, and have placed iron monuments as shown, and the same is correct.

Jens Pedersen
Surreyor.

State of Minnesota } ss.
County of Ramsey }

On this 8th day of FEB. 1910 personally came before me, the undersigned, Jens Pedersen, to me well known, and acknowledged that he executed the foregoing certificate as his own free act and deed.

W. J. Moore
Notary Public, Ramsey County, Minn.
My commission expires Oct. 28 1912

This is to certify that Richard A. Walsh and Margaret M. Walsh, his wife, proprietors of Lots 6 and 7, Block 22, West St. Paul Proper, have caused the same to be surveyed and platted, and hereafter to be known as THOMAS WALSH'S RE-ARRANGEMENT, as shown by this plat, and hereby dedicate to the public, and for the public use forever, all the streets and alleys herein indicated. Witness our hands and seals this 8th day of February 1910.

In presence of:
Sarah Walsh
Margaret Walsh

Richard A. Walsh (seal)
Margaret M. Walsh (seal)

State of Minnesota } ss.
County of Ramsey }

On this 9th day of February 1910 personally came before me, the undersigned, Richard A. Walsh and Margaret M. Walsh, his wife, to me well known, and acknowledged that they executed the foregoing certificate as their own free act and deed.

John W. Pirsch
Notary Public, Ramsey County, Minn.
My commission expires October 4th 1911.

Accepted and approved this 5th day of March 1910

J. J. Amman } Plat Commissioners
Joseph J. Jensen }
Wm. H. Redington } City Engineer

Accepted by the Board of Aldermen March 16 1910.
" " Assembly March 17 1910.
Approved March 27 1910.
Ed. J. Redington
City Clerk

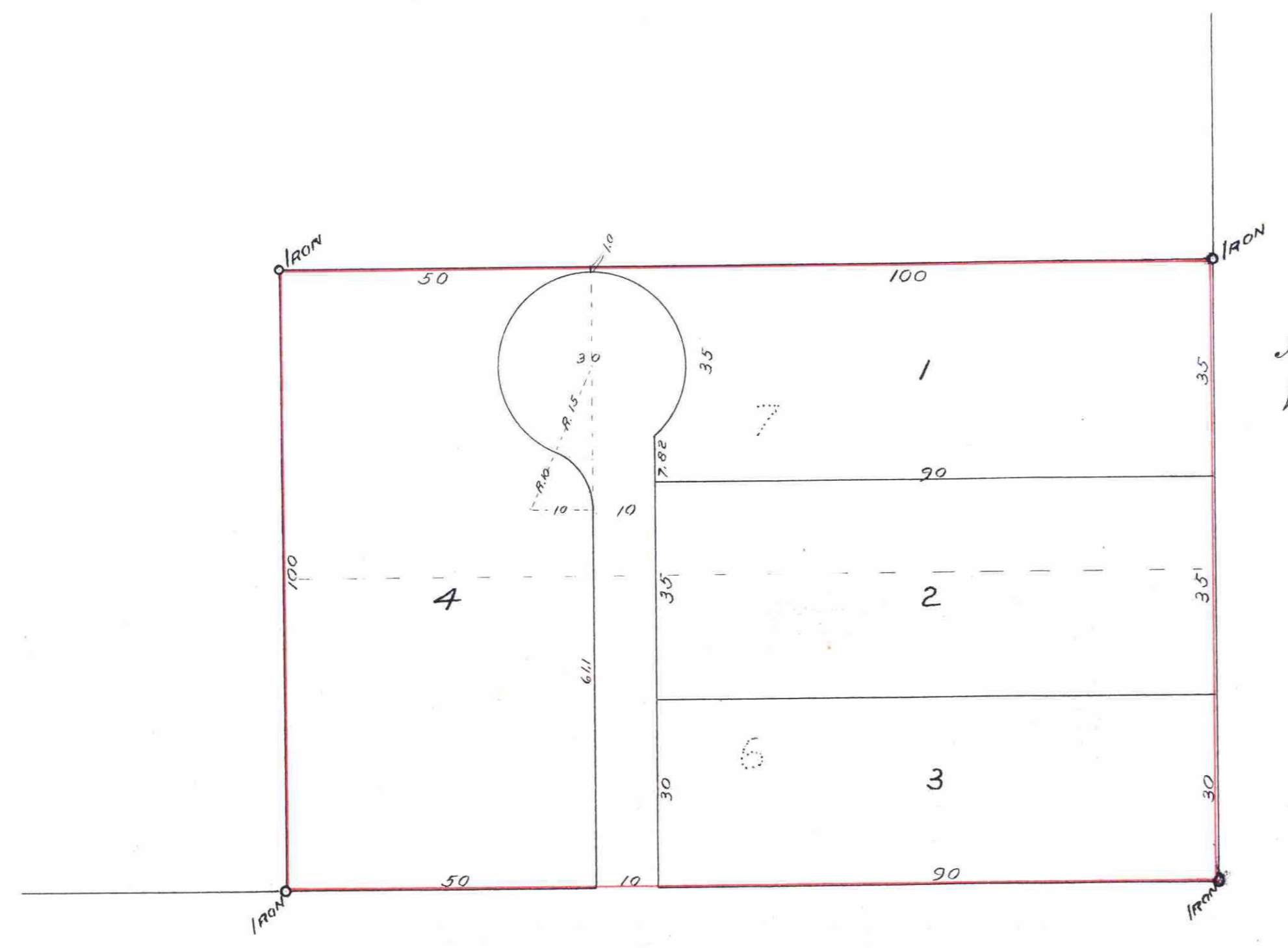

So. ROBERT ST.

DELOS ST.

STATE OF MINNESOTA,
County of Ramsey, ss.
Office of the Registrar of Deeds
This is to certify that the within instrument was filed for record in this office at St. Paul, Minn. on the 29th day of December, A. D. 1910 at 10 o'clock A. M., and that the same was duly recorded in Book 28 of *Deeds* Page 2.
Wm. H. Redington
Registrar of Deeds.

TAXES PAID
AND TRANSFER ENTERED
DEC 29 1910
EDW. KRANMER, Co. Auditor,
Wm. H. Redington Deputy.

CITY TREASURER'S OFFICE,
ST. PAUL, MINN.
DEC 29 1910
Assessed & PAID
By *Wm. H. Redington* City Treasurer

Taxes for the year 1910 on the lands hereof
DEC 30 1910
JESSE PATRICK, City Treasurer
Per *Wm. H. Redington*

440871