

# RAMSEY COUNTY HIGHWAY RIGHT OF WAY PLAT NO. 9 - C.S.A.H. 65 - WHITE BEAR AVENUE

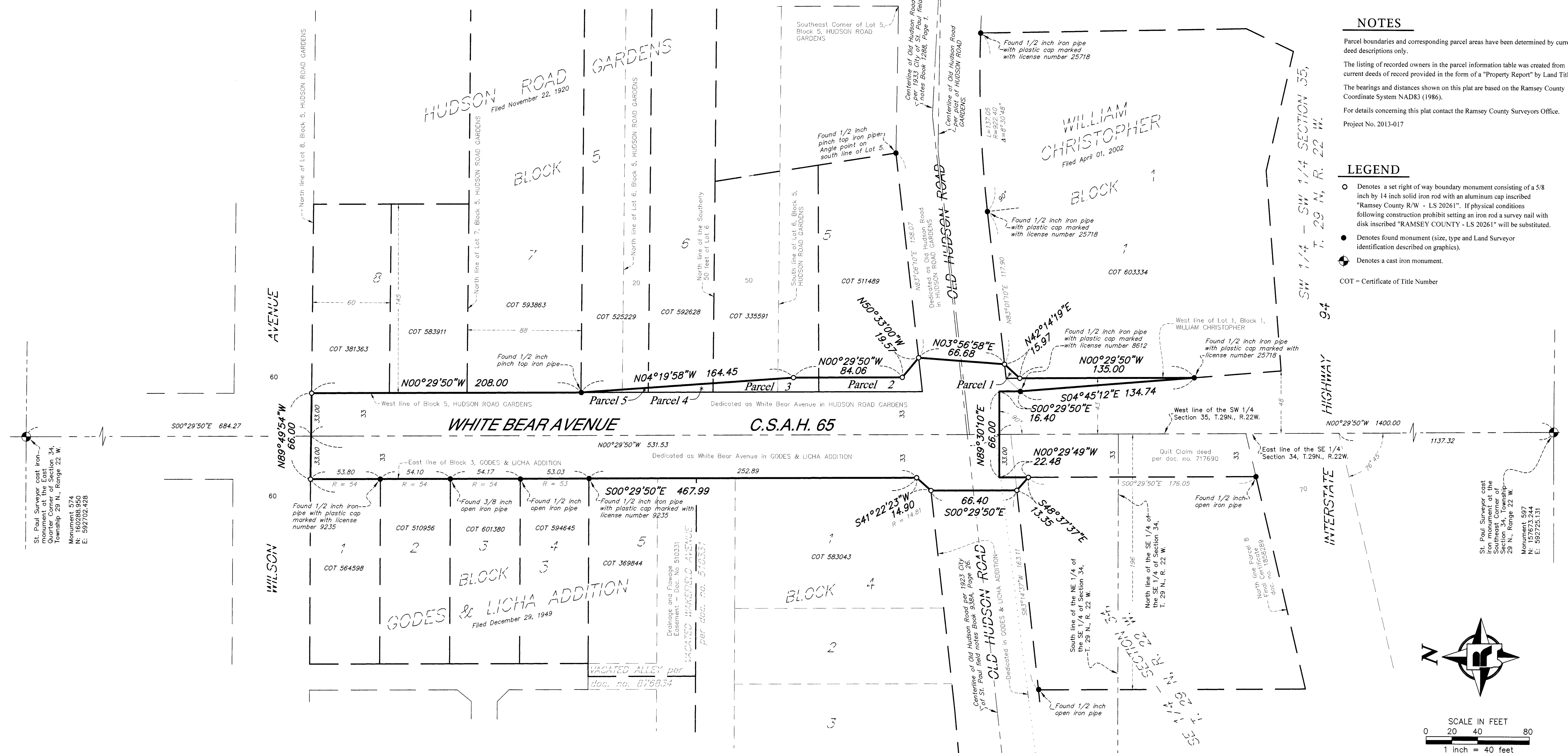

## NOTES

Parcel boundaries and corresponding parcel areas have been determined by current deed descriptions only.

The listing of recorded owners in the parcel information table was created from current deeds of record provided in the form of a "Property Report" by Land Title Inc.

The bearings and distances shown on this plat are based on the Ramsey County Coordinate System NAD83 (1986).

For details concerning this plat contact the Ramsey County Surveyors Office.

Project No. 2013-017

## LEGEND

- Denotes a set right of way boundary monument consisting of a 5/8 inch by 14 inch solid iron rod with an aluminum cap inscribed "Ramsey County R/W - LS 20261". If physical conditions following construction prohibit setting an iron rod a survey nail with disk inscribed "RAMSEY COUNTY - LS 20261" will be substituted.
  - Denotes found monument (size, type and Land Surveyor identification described on graphics).
  - ⊕ Denotes a cast iron monument.
- COT = Certificate of Title Number

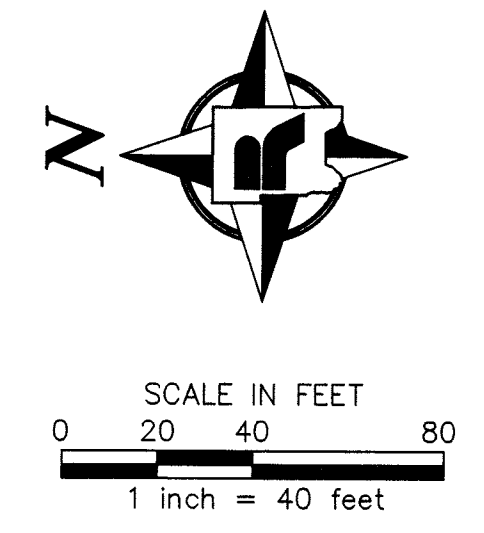

Pursuant to Minnesota Statutes, Section 160.085 and Section 160.14; and Resolution B2015-096 of the Board of Commissioners for Ramsey County, Minnesota, I hereby certify that this highway right of way plat is adopted to facilitate the acquisition and establishment of right-of-way for highway. This plat applies to that portion of County State Aid Highway No. 65 (White Bear Avenue), from Interstate Highway 94 to Wilson Avenue, which is located in Sections 34 and 35, Township 29 North, Range 22 West. The road authority may refer to this plat for purposes of establishment, acquisition or disposition of land identified herein.

*[Signature]*  
 James E. Tolaas, PE  
 Ramsey County Engineer  
 Minnesota License No. 16159

Date: 8/13/15

County Recorder, County of Ramsey, State of Minnesota

I hereby certify that this plat of RAMSEY COUNTY HIGHWAY RIGHT OF WAY PLAT NO. 9 - C.S.A.H. 65 - WHITE BEAR AVENUE was filed in the office of the County Recorder for public record on this 19<sup>th</sup> day of August, 2015, at 10 o'clock A. M. as Document Number 4571303

*[Signature]*  
 Deputy County Recorder

Registrar of Titles, County of Ramsey, State of Minnesota

I hereby certify that this plat of RAMSEY COUNTY HIGHWAY RIGHT OF WAY PLAT NO. 9 - C.S.A.H. 65 - WHITE BEAR AVENUE was filed in the office of the Registrar of Titles for public record on this 19<sup>th</sup> day of August, 2015, at 10 o'clock A. M. as Document Number 2537934

*[Signature]*  
 Deputy Registrar of Titles

I hereby certify that this plat was prepared by me or under my direct supervision and that I am a duly Licensed Land Surveyor under the laws of the State of Minnesota; that this plat meets the requirements of Minnesota Statutes, Section 160.085 and Section 160.14, Subdivision 1; that all monuments shown on the plat will be correctly placed in the ground upon the completion of construction as stated in the legend hereon; that all measurements are correctly shown on this plat; and that all right of way boundary lines are correctly designated on this plat.

*[Signature]*  
 Craig W. Anzman, LS  
 Ramsey County Surveyor  
 Minnesota License No. 20261

Date: August 13, 2015

PARCEL	OWNERS NAME	PROPERTY INFORMATION	SQUARE FOOTAGE			CERTIFICATE OF TITLE NUMBER	PROPERTY IDENTIFICATION NUMBER
			EXISTING HIGHWAY R/W	ADDITIONAL HIGHWAY R/W	TOTAL HIGHWAY R/W		
1	WEINFRA, LLC	Lot 1, Block 1, WILLIAM CHRISTOPHER	0	57	57	603334	35-29-22-33-0013
2	MGNUTT COMPANIES, INC.	Part of Lot 5, Block 5, HUDSON ROAD GARDENS	0	980	980	511489	35-29-22-32-0044
3	GAERTNER HOLDING CO. & CAPITOL CITY HOLDING CO.	Part of Lots 5 & 6, Block 5, HUDSON ROAD GARDENS	0	769	769	335591	35-29-22-32-0043
4	AMADOR OCHOA	Part of Lot 6, Block 5, HUDSON ROAD GARDENS	0	260	260	592628	35-29-22-32-0042
5	DARLENE M. SCHEIBEN	Part of Lots 6 & 7, Block 5, HUDSON ROAD GARDENS	0	93	93	525229	35-29-22-32-0041