

CENTURY TRAILS COMMONS

KNOW ALL MEN BY THESE PRESENTS: That St. Paul's Monastery, a Minnesota religious corporation, owner of the following described property situated in the City of Maplewood, County of Ramsey, State of Minnesota:

That part of the South Half of the Southeast Quarter of Section 13, Township 29, Range 22, Ramsey County, Minnesota, lying east and north of a line described as beginning at a point on the south line of said Southeast Quarter of Section 13, 985 feet west of the southeast corner of said Southeast Quarter of Section 13; thence deflecting to the right 78 degrees 40 minutes in a north-northwesterly direction for 620 feet to a point of curve; thence to the left on a curve having a radius of 100 feet a distance of 157.08 feet to a point of tangent; thence northwesterly deflecting to the right 90 degrees, at right angles to the tangent to said curve at said point of tangent, a distance of 450 feet; thence deflecting to the left 90 degrees a distance of 200 feet; thence deflecting to the right 90 degrees a distance of 225 feet, more or less, to the north line of said South Half of the Southeast Quarter of Section 13;

Which lies easterly, northerly and easterly of a line described as commencing at said southeast corner of the Southeast Quarter of Section 13; thence westerly, along said south line of the Southeast Quarter of Section 13, a distance of 832.02 feet to the point of beginning of the line to be described; thence deflecting to the right 78 degrees 40 minutes 00 seconds a distance of 750.06 feet; thence deflecting to the left 90 degrees 00 minutes 00 seconds a distance of 204.00 feet; thence deflecting to the right 90 degrees 00 minutes 00 seconds a distance of 638.98 feet to said north line of the south half of the Southeast Quarter of Section 13;

Except that part of the Southeast Quarter of said Southeast Quarter of Section 13 which lies northeasterly of a line parallel with and distant 100 feet southwesterly of a line described as beginning at a point on the east line of said Section 13, distant 1324.13 feet north of the southeast corner thereof; thence run westerly at an angle of 90 degrees with said east section line for 186.63 feet; thence deflect to the right on a 10 degree curve, delta angle 29 degrees 20 minutes, for 293.33 feet; thence on tangent to said curve for 100 feet and there terminating;

Also except all that part of the above described tract, adjoining and southerly of the above described strip, which lies easterly of a line run parallel with and distant 60 feet westerly of the following described line: Beginning at the point of intersection of the above described line with the east line of said Section 13; thence run southerly along the east line of said Section 13 for 540 feet and there terminating;

Also except a triangular piece adjoining and southerly of the first above described strip and westerly of the last described strip, which lies northeasterly of the following described line: From a point on the last described line, distant 150 feet southerly of its point of beginning, run westerly at right angles to said line for 60 feet to the point of beginning of the line to be described; thence run northwesterly to a point on the southerly boundary of the first above described strip, distant 100 feet westerly of its intersection with a line run parallel with and distant 33 westerly of the east line of said Section 13.

Has caused the same to be surveyed and platted as CENTURY TRAILS COMMONS and does hereby dedicate to the public for public use forever the public ways and the drainage and utility easements as shown on this plat.

In witness whereof said St. Paul's Monastery, a Minnesota religious corporation, has caused these presents to be signed by its proper officer this 7th day of May, 2008.

Signed: St. Paul's Monastery
Dr. Carol Rennie its President

STATE OF Minnesota
COUNTY OF Ramsey

The foregoing instrument was acknowledged before me this 7 day of May, 2008
by S. CAROL RENNIE PRESIDENT of St. Paul's Monastery, a Minnesota religious corporation, on behalf of the corporation.

Mary Catherine Courtson

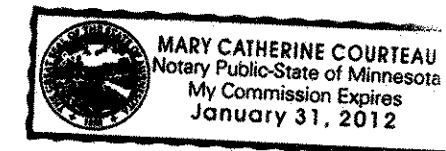

Notary Public, State of Minnesota County, Ramsey
My Commission Expires January 31, 2012

I, Mark S. Hanson, professional land surveyor, do hereby certify that I have surveyed or directly supervised the survey of the property described on this plat; prepared this plat or directly supervised the preparation of this plat; that this plat is a correct representation of the boundary survey; that all mathematical data and labels are correctly designated on this plat; that all monuments depicted on this plat have been correctly set; that all water boundaries and wet lands, as defined in Minnesota Statutes, Section 505.01, Subd. 3, as of the date of the surveyor's certification are shown and labeled on this plat; and all public ways are shown and labeled on this plat.
Dated this 7th day of MAY, 2008.

Mark S. Hanson
Mark S. Hanson, Professional Land Surveyor
Minnesota License No. 15480

STATE OF MINNESOTA
COUNTY OF HENNEPIN

The foregoing Surveyor's Certificate was acknowledged before me this 7th day of May, 2008, by Mark S. Hanson, a Licensed Land Surveyor.

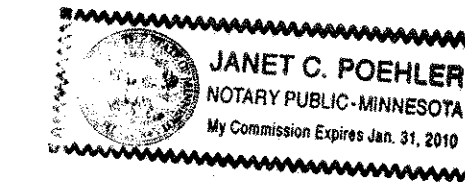

Janet C. Poehler
Janet C. Poehler
Notary Public, Hennepin County, Minnesota
My Commission Expires January 31, 2010

City of Maplewood, Minnesota
We do hereby certify that on the 14th day of April, 2008, the City Council of the City of Maplewood, Minnesota, approved this plat. Also the conditions of Minnesota Statutes, Section 505.03, Subd. 2, have been fulfilled.

Wana Stangie, Mayor Karen E. Gumpel, Clerk

Department of Property Records and Revenue

Pursuant to Minnesota Statutes, Section 505.021, Subd. 9, taxes payable in the year 2008 on the land hereinbefore described have been paid. Also, pursuant to Minnesota Statutes, Section 272.12, there are no delinquent taxes and transfer entered this 12th day of May, 2008.

Mark Oswald, Director
Department of Property Records and Revenue
By Mary Kay Simpson, Deputy

County Surveyor

I hereby certify that this plat complies with the requirements of Minnesota Statutes, Section 505.021, and is approved pursuant to Minnesota Statutes, Section 383A.42, this 14 day of May, 2008.

By David D. Claypool, Deputy
David D. Claypool, P.L.S., Ramsey County Surveyor

County Recorder, County of Ramsey, State of Minnesota

I hereby certify that this plat of CENTURY TRAILS COMMONS was filed in the office of the County Recorder for public record on this 15th day of MAY, 2008, at 8:00 o'clock A. M. and was duly filed in Book 123 of Plats, Pages 35 and 36, as Document Number 4096573.

Deputy County Recorder



CENTURY TRAILS COMMONS

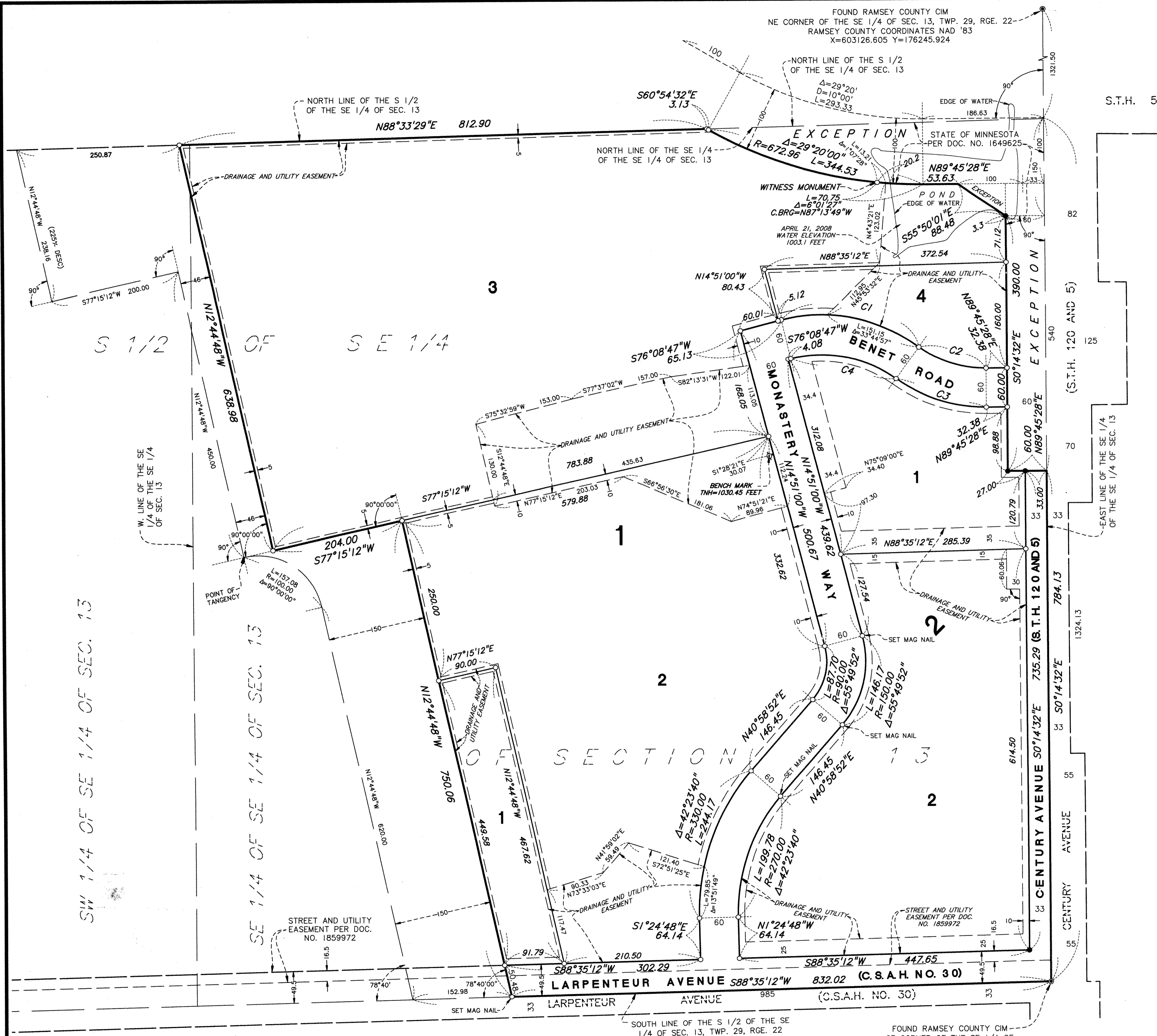

S.T.H. 5

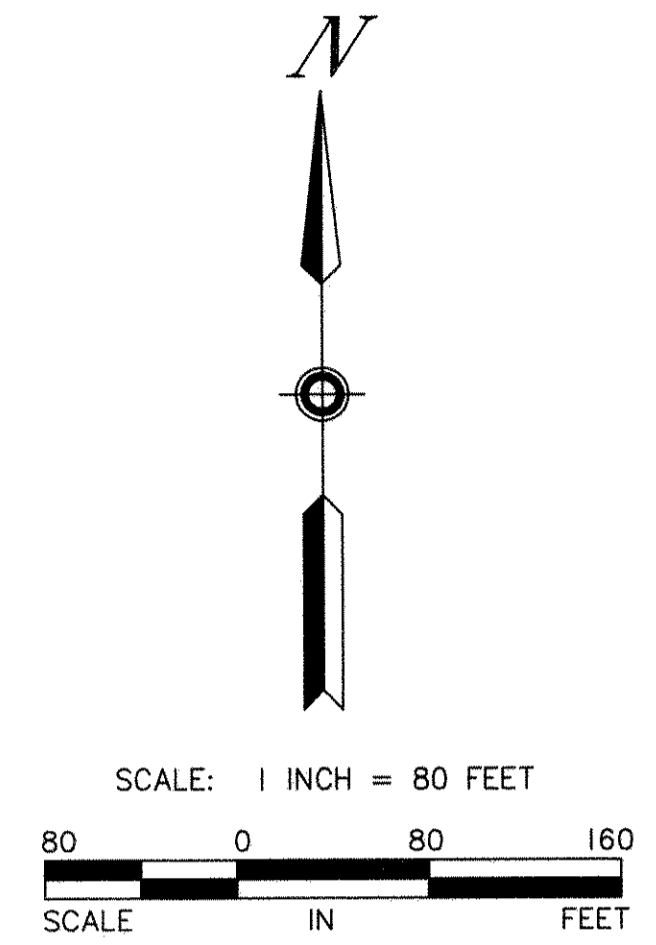
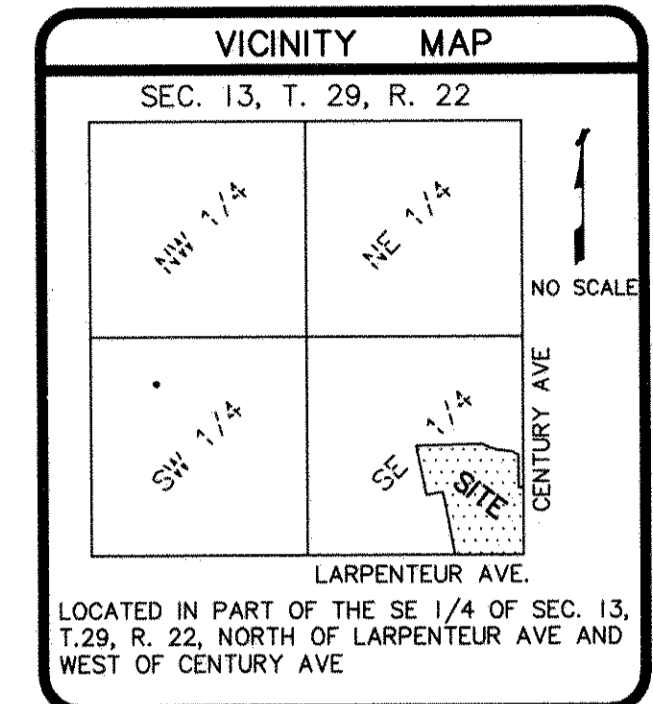

CURVE TABLE			
C1	Δ=49°43'58"	R=256.80	L=222.73
C2	Δ=36°07'17"	R=175.00	L=110.33
C3	Δ=36°07'17"	R=235.00	L=148.15
C4	Δ=49°43'58"	R=196.60	L=170.85

DRAINAGE AND UTILITY EASEMENTS ARE SHOWN THUS:

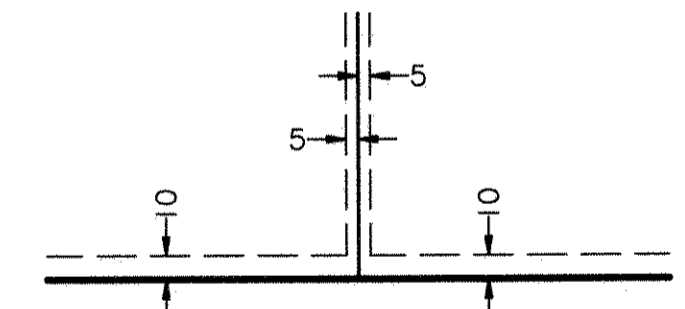

BENCH MARK: All elevations refer to the top of top nut of fire hydrant (TNH)
Elevation = 1030.45 feet (N.G.V.D. 1929)

- DENOTES 1/2 INCH BY 14 INCH IRON PIPE SET AND MARKED WITH LICENSE NO. 15480 UNLESS NOTED OTHERWISE
- DENOTES FOUND 1/2 INCH BY 14 INCH IRON PIPE MARKED WITH LICENSE NO. 15480 UNLESS NOTED OTHERWISE

Bearings for this plat are based on the east line of the Southeast Quarter of Section 13, Township 29, Range 22, having an assumed bearing of S0°14'32"E.