

# FORD MOTOR COMPANY FIRST ADDITION

C. E. COULTER & ASSOCIATES, INC.  
LAND SURVEYORS

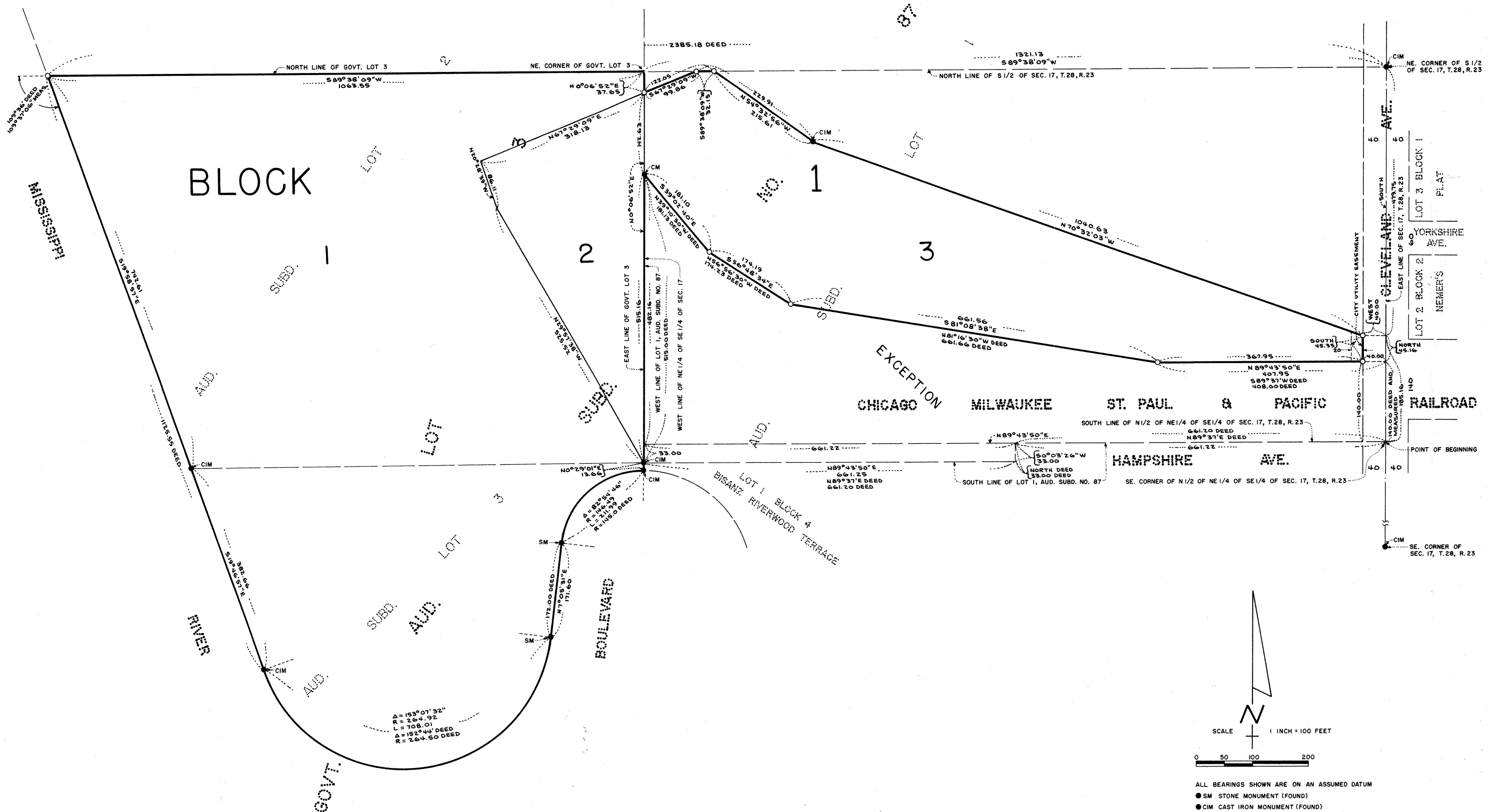

3401  
John Peterson  
11-25-75

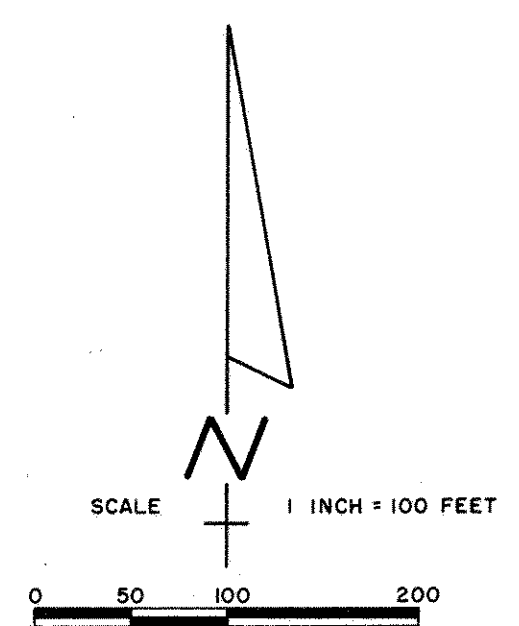

- ALL BEARINGS SHOWN ARE ON AN ASSUMED DATUM
- SM STONE MONUMENT (FOUND)
- CIM CAST IRON MONUMENT (FOUND)
- CM CONCRETE MONUMENT WITH REINFORCING ROD CENTER (FOUND)
- 5 INCH DIAMETER IRON PIPE FILLED WITH CONCRETE (PLACED)
- ALL DISTANCES SHOWN ARE MEASURED UNLESS OTHERWISE NOTED

Abstract # 1922309 3401