

**DESCRIPTION OF PROPERTY SURVEYED**

Lot 8, Block 2, STINSON'S RICE STREET ADDITION, according to the recorded plat thereof, Ramsey County, Minnesota.

Property is located in Ramsey County, Minnesota.

**PLAT RECORDING INFORMATION**

The plat of STINSON'S RICE STREET ADDITION was filed of record on October 5, 1884, in Book V of Plats, page 32.

[ ] Bearings and/or dimensions listed within brackets are per plat or record documents.

**TITLE COMMITMENT**

Stewart Title Guaranty Company Commitment for Title Insurance File No. 346138, effective date June 7, 2010, was relied upon as to matters of record.

**GENERAL NOTES**

- 1.) Adjoining ownership information shown hereon was obtained from the Ramsey County Property Tax Information web site. Ownership information is subject to revision upon receipt of a title search by a title insurance company.
- 2.) Coordinate basis: Ramsey County System (North American Datum of 1983 Coordinates, final adjustment December 17, 1991)
- 3.) Right of way easement described per quit claim deed from the City of Saint Paul.

**UTILITY NOTES**

- 1.) Utility information from plans and markings was combined with observed evidence of utilities to develop a view of the underground utilities shown hereon. However, lacking excavation, the exact location of underground features cannot be accurately, completely and reliably depicted. Where additional or more detailed information is required, excavation may be necessary.
- 2.) Other underground utilities of which we are unaware may exist. Verify all utilities critical to construction or design.
- 3.) Some underground utility locations are shown as marked onsite by those utility companies whose locators responded to our Gopher State One Call, ticket number 111100665.
- 4.) Contact GOPHER STATE ONE CALL at 651-454-0002 (800-252-1166) for precise onsite location of utilities prior to any excavation.

**FLOOD ZONE NOTES**

- 1.) The subject property appears to lie within Zone X, (Areas determined to be outside the 0.2% annual chance floodplain), per the National Flood Insurance Program, Flood Insurance Rate Map Community Panel No. 275248010IG, dated June 4, 2010. (This information was obtained from the FEMA web site at www.msc.fema.gov)

**ZONING NOTES**

- 1.) Zoning information obtained from the City of Saint Paul web site on April 20, 2011. The subject property is zoned R4.
- 2.) The setbacks for zone R4(one-family) are:  
Building: Front = 25 feet  
Side = 4 feet  
Rear = 25 feet

Note: See sec. 66.231 of the Saint Paul zoning code for additional standards which may apply.

**AREAS**

Area = 4,942 sq. ft. or 0.113 acres.

**LEGEND**

AGP	Denotes above ground pipe
BE	Denotes building entrance
CBOX	Denotes control box
CLP	Denotes clothes line pole
CS	Denotes curb stop
CST	Denotes concrete steps
DISH	Denotes satellite dish
EM	Denotes electric meter
FF	Denotes finished floor
FW	Denotes face of walk
GM	Denotes gas meter
GP	Denotes guard post
GW	Denotes guy wire
HHE	Denotes electric hand hole
INV	Denotes invert of pipe
LP	Denotes light pole
OD	Denotes overhead door
OHC	Denotes overhead communication line
OHE	Denotes overhead electric line
(P)	Denotes utility or structure per plan
PP	Denotes power pole
PPLP	Denotes power and light pole
PPU	Denotes power pole with underground electric
RD	Denotes roof drain
SAN	Denotes sanitary sewer manhole
SAN S	Denotes sanitary sewer
TC	Denotes top of concrete curb
TCS	Denotes traffic control sign
UGE	Denotes underground electric
W	Denotes water line
WV	Denotes water valve
WW	Denotes window well
BIR	Denotes Birch tree
MPL	Denotes Maple tree

**BENCH MARKS (BM)**  
(NGVD 1929)

- 1.) Top of top nut of fire hydrant at northeast corner of Maryland Avenue and Sylvan Street. Elevation = 868.96 feet
- 2.) Top of top nut of fire hydrant at northwest corner of Maryland Avenue and Park Street. Elevation = 855.99 feet
- 3.) Top of bolt at northeast corner of light pole on south side of Maryland Avenue, in front of 112 Maryland Avenue. Elevation = 859.30 feet

NOTE: Elevations shown are based on mean sea level datum. Subtract 694.10 to convert to the City of St. Paul datum.

**SURVEYOR'S CERTIFICATION**

To: Stewart Title Guaranty Company, City of Saint Paul, and Ramsey County

This is to certify that this map or plat and the survey on which it is based were made in accordance with the 2011 Minimum Standard Detail Requirements for ALTA/ACSM Land Title Surveys, jointly established and adopted by ALTA and NSPS. The field work was completed on April 22, 2011.

Dated this 29th day of April, 2011.

SUNDE LAND SURVEYING, LLC.

By: *Mark S. Hanson*  
Mark S. Hanson, P.L.S. Minn. Lic. No. 15480

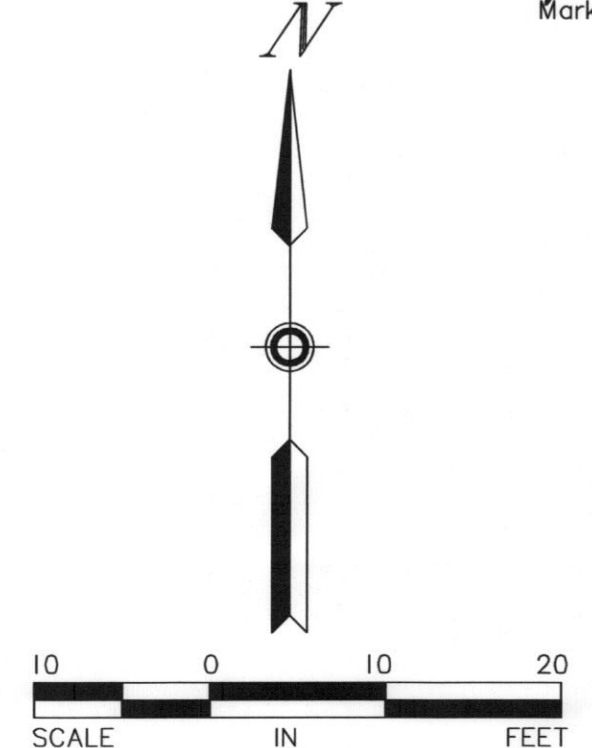
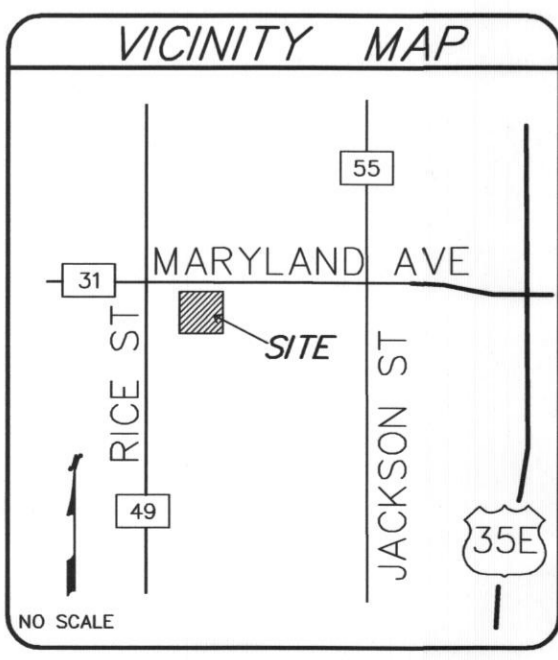

Revision	By	Date
Drawing Title:		
ALTA/ACSM LAND TITLE SURVEY FOR:		
RAMSEY COUNTY PUBLIC WORKS		
116 MARYLAND AVENUE		
<b>SUNDE</b>		Main Office:
LAND SURVEYING		9001 East Bloomington Freeway (35W) • Suite 118
www.sunde.com		Bloomington, Minnesota 55420-3435
Project: 2011-043		Blk/Pg: 938/21
Township: 029 Range: 22		Section: 30
File: 2011043001.dwg		Date: 04/29/2011
		Sheet: 1 of 1